



YOKOJI-ZEN MOUNTAIN CENTER

\$12,000 NEEDED TO UPGRADE OFF-GRID SYSTEM

Yokoji has a strong ecological basis, stemming from the need to exist in harmony with the mountain, and in line with the Zen tradition of living lightly on the land. We want to build on this, making Yokoji sustainable for future generations. With limits on time, money and skills, we will be asking for your help over the coming years. Major construction at Yokoji is now over after 29 years and we are entering a new phase. Focus can now be switched to ongoing maintenance, beautification, and new ways of preserving our precious resources.

Current Ecological Measures

- ✓ Off-grid power system, largely renewable energy
- ✓ Energy conservation integral to the Yokoji guidelines
- ✓ All water drawn from on-site wells
- ✓ Composting and recycling programs in place
- ✓ 100% vegetarian, largely organic diet
- ✓ Minimized use of propane heaters

Future Ecological Measures

- ✓ Building of greenhouses to grow our own produce
- ✓ Reduction of reliance on fossil fuels by the following:
 - Construction of solar ovens to reduce propane usage
 - More solar panels (see below)

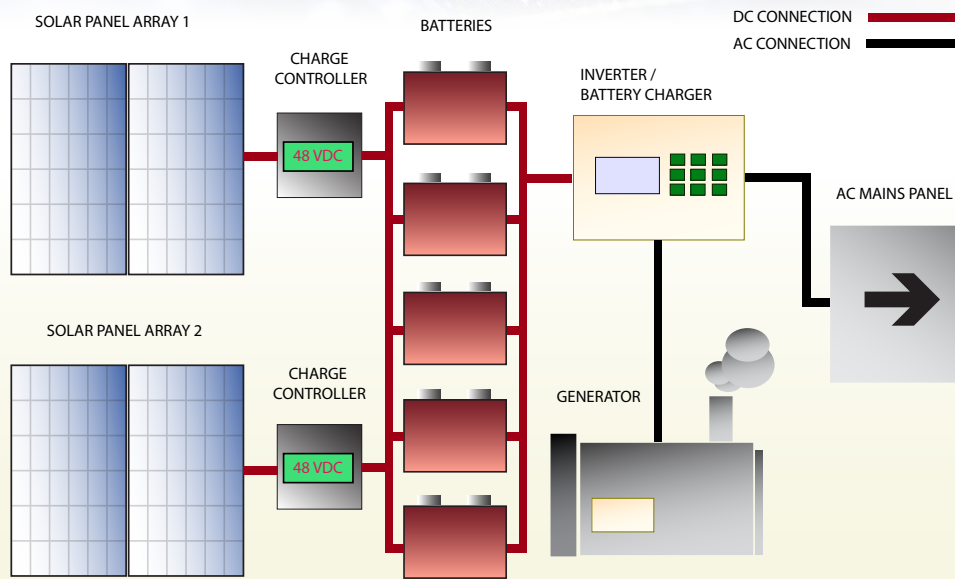

Our current energy needs are not being met by renewable sources alone. We rely heavily on a diesel generator throughout the year. We hope to purchase more solar panels (\$5,000 - 7,000) as well as upgrade our charge controllers (which control the energy going in to the batteries from the panels - \$1,200) and our inverter (changes the power from 24V DC to 120V AC and takes power from the generator to charge the batteries - \$3,500).

We will need around \$2,000 for electrician's fees and cables, breaker boxes and other miscellaneous items.

The diagram shows our current system. The upgrades will improve the performance and efficiency of the system as well as increasing our renewable energy input by about 30%. This means we can spend less money on fuel while conserving the environment.

Please help us, however and where ever you can. Thank you.

Name:

Email:

Address:

I would like to pledge: \$50.00 \$100.00 \$250.00 \$500.00 \$1,000.00 Other \$.....

Payment method: Check Credit Card (Visa/Mastercard) or PayPal at www.zmc.org/donate

Credit Card #: _____ Expiration: ____ / ____ CVV: ____

If you would rather donate to the scholarship fund, general operations or to any other area of the Center, please let us know. We are a non-profit organization, so your donation is tax deductible. We will send out a receipt for each donation as well as an end of year summary of all donations received for your tax records. **Thank you!**